

ANNOUNCED SPECIFICATION OF HS-75BB RETRACT SERVO

1. TECHNICAL VALUES

CONTROL SYSTEM	: +PULSE WIDTH CONTROL 1500usec NEUTRAL	
OPERATING VOLTAGE RANGE	: 4.8V TO 6.0V	
OPERATING TEMPERATURE RANGE	: -20 TO +60°C	
TEST VOLTAGE	: AT 4.8V	AT 6.0V
OPERATING SPEED	: 0.45sec/60° AT NO LOAD	0.34sec/60° AT NO LOAD
STALL TORQUE	: 6.6kg.cm(91.65oz.in)	8.2kg.cm(113.87oz.in)
OPERATING ANGLE	: 170°ONE SIDE PULSE TRAVELING 400usec	
DIRECTION	: CLOCK WISE/PULSE TRAVELING 1400 TO 1600usec	
CURRENT DRAIN	: 1mA/IDLE AND 150mA/NO LOAD RUNNING	
DEAD BAND WIDTH	: 20usec	
CONNECTOR WIRE LENGTH	: 300mm(11.81in)	
DIMENSIONS	: 44x23x25mm(1.73x0.90x0.98in)	
WEIGHT	: 35g(1.23oz)	

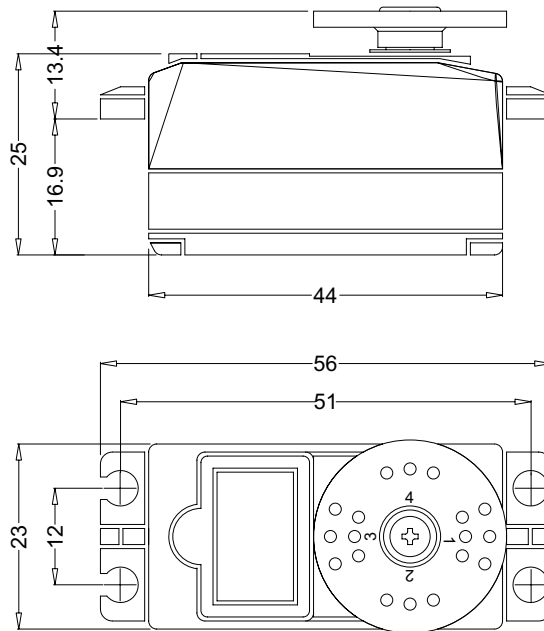

2. FEATURES

- 3-POLE FERRITE MOTOR
- LONG LIFE POTENTIOMETER
- WATER AND DUST TIGHT
- INDIRECT SWITCH DRIVE
- ONE METAL AND FOUR POM RESIN GEARS
- ONE BALL BEARING
- HYBRID I.C

3. APPLICATIONS

- RETRACT SERVO FOR AIRCRAFT
- 180° ROTATION