

BD10-CAN General Specification.

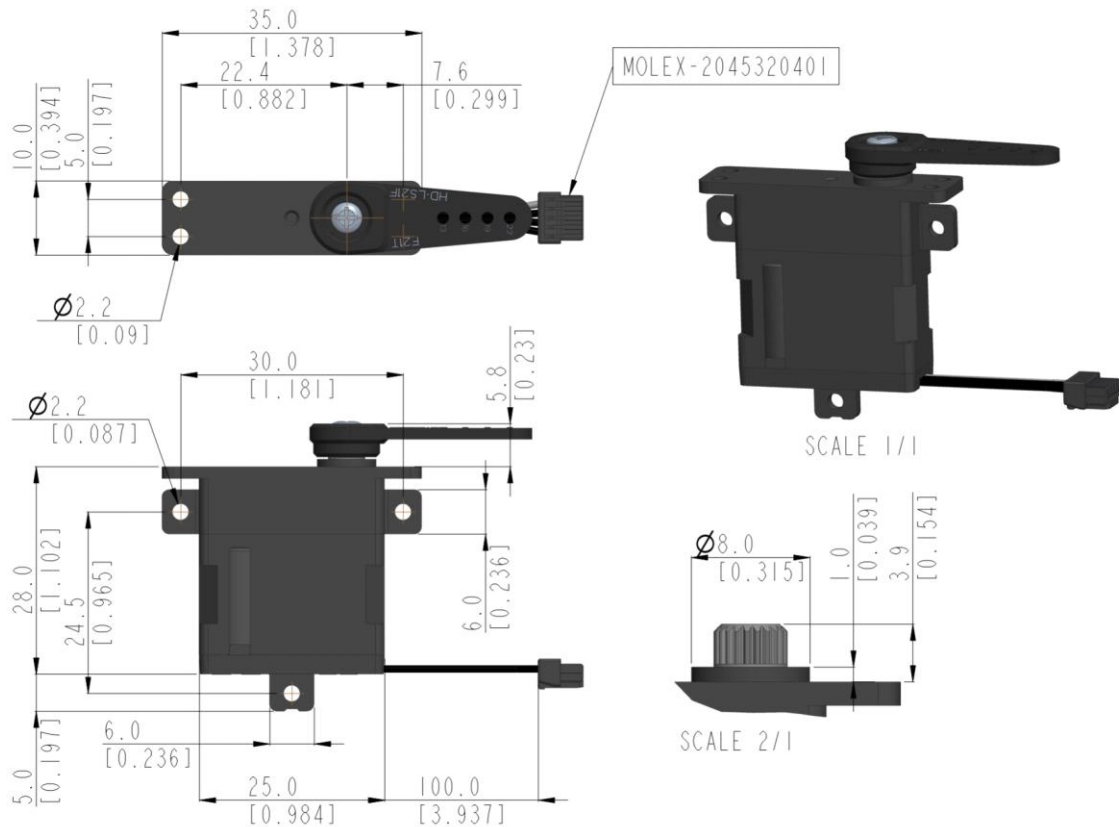

Control System	CAN 2.0A,B		-
Position Sensor Type	Contactless Magnetic Encoder		-
Motor Type	BLDC		At the Max voltage, it is recommended to be used only for a short time duration.
Operating Voltage Range	4.0 ~ 8.4V		
Voltage	-	6.0V	7.4V
No Load Speed	-	0.12sec/60°	0.09sec/60°
Stall Torque	-	2.2kgf-cm (30.55oz-in)	2.8kgf-cm (38.88oz-in)
Peak Efficiency Torque	-	0.4kgf-cm (5.55oz-in)	0.6kgf-cm (8.33oz-in)
Standing Current	-	30mA	30mA
No Load Running Current	-	120mA	120mA
Stall Current	-	820mA	1,000mA
Deadband	-	n/a	n/a
Operating Travel	Servo Mode : ±60°(Default), ±150°(Programmable)		-
Operating Temperature Range	-40°C ~ +70°C (-40°F ~ +158°F)		-
Storage Temperature Range	-40°C ~ +80°C (-22°F ~ +176°F)		-
Connector	Molex 2045320401 (Mating Header : 2059570471)		
Connector Wire Length	100mm (3.937inch)		
Connector Wire Gauge	28AWG		
Dimensions	25.0mm x 10.0mm x 28.0mm (0.984inch x 0.394inch x 1.102inch)		General Tolerance ±0.1mm
Weight	11.8g (0.416oz)		Excluding the weight of Horn
Bearing Type	2 Ball Bearing		-
Case Material	Super Engineering Plastics		-
Gear Material	5 Super Engineering Plastic Gears		-
Gear Train Backlash	Max 0.5°		-
Horn Gear Spline	21T(Ø5)		-
IP-Rating	IP4X		-
Servo Amplifier Type	32bit programmable Digital		-



1:1 scale (Unit : mm[inch])

- This product should not be used directly on the human body for medical purposes.
- This product should not be used for war weapons.
- All specifications are subject to change without notice.
- Be careful as strong magnetic fields may cause malfunction of the product.

